

# TecTern TWO



## TecTern TWO – putting AV support at the presenter's finger tips

The TecTern TWO Technology Lectern is an exciting development for interactive presentations. Today's presenters are required to have stimulating graphic support to ensure their ideas are clearly understood especially in large venues like lecture halls. This calls for the use of technology at the lectern, and TecTern answers that challenge by integrating contemporary design with logical technology management, all at the presenter's fingertips.

### Powerful Storage Options

TecTern TWO features the sleek design made popular by TecTern, and features a fixed-height crown with a pullout laptop shelf, iPad® docking system, security locks on all doors and drawers, interior cable access area, interior pullout drawer, interior rack area and removable Modesty Panel for wiring of rack mounted components. LS Models feature an optional ready-to-present iPad mount and iPad-to-projector connection cable.

### Integrated Technology Management

Lid closed, TecTern is in its simplest form—a flat, clean top with a document rail. Opening (or simply lifting off) the bi-fold lid reveals many features: a laptop tray, a spacious cavity for connections and cable management and room for TeamBoard Finger Touch Monitor.

### Mobility & Positioning

TecTern's steel base ensures stability and the two lockable, heavy duty casters make it easy to reposition to a new location.

### Interactive Presentation Control with TecTern Total

Interactive presentations are now possible in lecture halls, theatres, and other large-audience settings. Fully integrated into the unit, TecTern has an optional built-in, finger touch display. This allows presenters to control their large-screen presentation, eliminating the need for a mouse, remote or keyboard. TecTern adds functionality to make your presentations come alive with digital ink annotations and more, all with the touch of a finger. The included TeamBoard Draw Software provides annotation and many other vital presentation tools.

TEAM  
BOARD

easy  
does it.®

## TecTern TWO

### Product Codes

**TecTern TWO with LapTop Shelf**  
T2LS Series

**TecTern TWO with Finger Touch Monitor**  
T2TM Series

**Custom configurations are available**

Please also visit  
[www.teamboard.com/library](http://www.teamboard.com/library)



## Features

## Benefits

TecTern TWO T2LS TecTern TWO T2TM	✓ Ample Storage	> Pullout laptop shelf, security locks on all doors and drawers, interior cable access area, interior pullout drawer, interior rack area and removable Modesty Panel for wiring of rack mounted components
	✓ Bi-fold work surface lid	> Provides easy access to technology including laptop and Finger Touch Monitor > When closed, the flat surface offers a document rail for notes, and is suitable for mouse use. The hard surface is also suitable as a writing deck. > The bi-fold feature keeps the lid profile low when in the open position, to avoid a visual barrier between presenter and audience
	✓ Modesty panel	> The removable Modesty Panel provides easy access for wiring of rack mounted components
	✓ Cavity below deck	> Accommodation below deck to store laptop and all the connections, power supplies and cable management required for the presentation
	✓ Laptop shelf with secure door	> Laptop Drawer and shelf has a lock to help keep laptop (not included) tucked away and slides out for easy access.
	✓ iPad® Shelf	> iPad® docking station and connection - folds flat when not in use.
	✓ Locking capability	> Locking security, keeping all equipment safe
	✓ Heavy base	> Keeps TecTern TWO stabilized in location
	✓ Easy Glide	> Allows the TecTern TWO to relocate and reposition when necessary
	✓ Colors	> Customize your colors: TecTern crown and modesty panel may be specified in any of the Egan Etex colors independently; modesty panel veneer options available
	✓ Design room on front of TecTern TWO	> Up to 15" wide and 12" high space on front panel of TecTern TWO available for a custom, factory-installed company logo or crest
	✓ Finger Touch Monitor (19"/16:10)	> Allows finger touch interactive control of a presentation right at the display –no need to walk around the room with a pointer > 19" display permits easy visibility of the presentation while facing the audience. 16:10 native aspect ratio matches that of modern projectors, but also works with 4:3 or 16:9 presentations > Command the presentation easily and smoothly with the touch of a finger and without a mouse, remote, keyboard or a helper
	✓ Screen adjustment	> The finger touch display is fully integrated with the TecTern TWO, cables and repositionable hardware mount > The 10-45° tilt range allows full visibility and multiple presenter angles or TecTern TWO heights to suit each presenter's preference
	✓ TeamBoard Draw software	> Permits digital ink annotations at the touch of a finger > Easily save your notes for distribution later in popular file formats > Many other presentation tools included for dynamic interaction



Customize your colors: TecTern TWO crown and modesty panel may be specified in any of the Egan Etex colors or wood veneer independently; see price list.



## Design Intent

TecTern incorporates contemporary lectern design with *easy does it* technology management. With the Finger Touch Monitor, interactive control of the presentation is simple even in large audience environments.

### Operating Specifications – TecTern TWO

Functionalities	Non interactive—open or closed Fully interactive—when equipped with Finger Touch Monitor (bundled or sold separately)
Construction	Designed, engineered and manufactured in North America Robust steel, wood and ABS plastic construction Etex finish with custom colors available
Warranty	5 years (lectern materials and workmanship only —see published price and specifications guide)
Certifications or Compliances	The management systems governing the design and manufacture of this product are ISO 9001:2008 and ISO 14001:2001 certified

*Your finger is the mouse!*



### Operating Specifications – Optional Finger Touch Monitor

Functionalities	Standard LCD high resolution monitor Full interactive touchscreen (finger touch) No pen required; stylus use optional Inputs: DVI-D, VGA 15 pin D-sub, USB
Image Specifications	Size: 19" viewable image area Pixel pitch: 0.284mm Brightness: 300 cd/m2 typical Contrast ratio: 700:1 Viewing angle: 160° vertical; 170° horizontal Response time: 5ms
Resolution	1440 x 900 @ 60 Hz native
Aspect Ratio	16:10 widescreen format, thin-frame (bezel)
Power Specifications	42W / 2W 110/240V (50/60Hz Power consumption operational) Standby/sleep 2 watts
Software	Certified TeamBoard Suite compliant ISO 13406-2 Class II, Windows Vista, Windows 7 compliant
Environment Conditions	Operating: 5-35° C / 41-95° F Humidity tolerance: 10-80% Altitude: 3048m /10,000 ft Storage temperature: -10-60° C /14-140° F Storage humidity: 10-85% non-condensing Storage altitude: 12,192m / 40,000 ft.
Warranty	Limited Warranty – North America: 2 years parts and labor, including backlight Limited Warranty – International warranties: call to inquire

### Key Features

**Finger Touch Control:**  
Control computer presentations and applications with available touch sensitive display.

**Contemporary design:** Sleek, modern design with minimalist appearance suits any presentation situation.

**No Hassle:** If you have any problems, pick up the phone and let us know. We expect and need our customers to be delighted with our products and services.



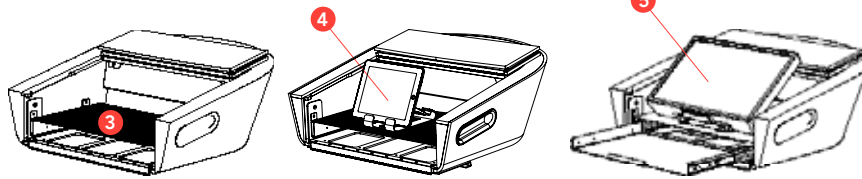
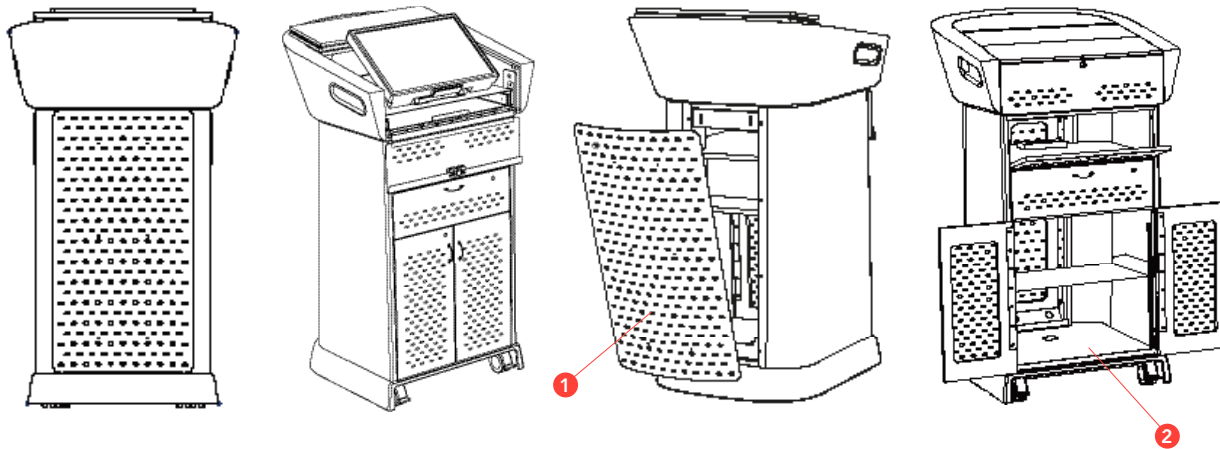

- 1 Removable Modesty Panel for access
- 2 Ample Storage with AV-Racking
- 3 Laptop Shelf T2LS
- 4 iPad® docking station
- 5 Finger Touch Monitor T2TM

## What's in the box...

### TecTern TWO (T2LS)

- TecTern Technology Lectern, fully assembled and finished
- Quickstart guide
- Owner's manual

### TecTern TWO (T2TM)

- TecTern TWO as described above
- Technology Integration Kit, pre-installed into TecTern
- Finger Touch Monitor, pre-installed into TecTern
- TeamBoard Draw Software (Windows, Mac OSX, Linux)

### TecTern Integration Kit (TPMT19TLIK)

- Installation brackets
- Cable and video splitter
- 110V AC expander

### Finger Touch Monitor (TPMT19)

- 19" Widescreen Finger Touch Monitor
- TeamBoard Draw Software

### Not included with any of the above:

- Extension cord (required) to supply power from outlet to TecTern TWO, computer, data projector

## Dimensional Details

Size: 27<sup>1/2</sup>"W x 47"H x 24<sup>7/8</sup>"D

Shipping: 300 lbs. (136.4kg)

Shipping box: 33"W x 53"H x 33"D

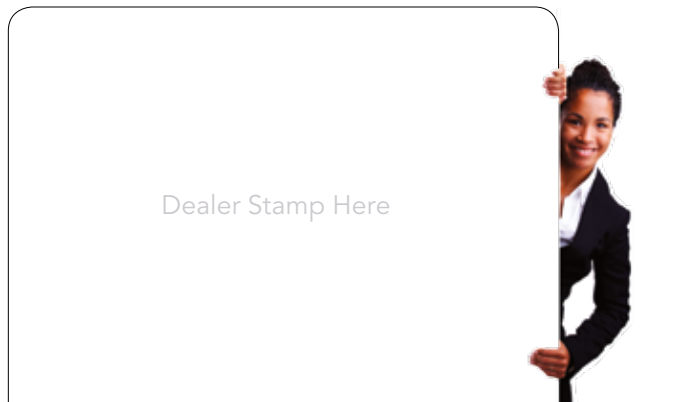

Designed and manufactured in North America by Egan TeamBoard Inc., leaders in the Interactive Whiteboard marketplace for 15 years. TeamBoard is part of the Egan Visual family, designers and manufacturers of visual communication products for over 40 years. You can count on TeamBoard products to be well-designed and well-built for years of hassle-free enjoyment.

**Environmentally responsible design, quality, value and timeliness.** Egan TeamBoard Inc. has been certified by UL™ to have established, documented, implemented and continuously maintains a Quality Management System and Environmental Management System, as a registrant of the ISO 9001:2008 and ISO 14001:2004 standards. iPad® is a registered trademark of Apple Inc. registered in the U.S. and other countries.



**Egan TeamBoard, Inc.**  
International

Tel +1-905-851-2826  
Fax +1-905-851-3426

[www.egan.com](http://www.egan.com)  
[www.teamboard.com](http://www.teamboard.com)

**Egan TeamBoard, Inc.**  
US Eastern / Central States & Canada

Tel +1-905-851-2826 1-800-263-2387  
Fax 1-888-609-8886

[sales@teamboard.com](mailto:sales@teamboard.com)

**Egan TeamBoard, Inc.**  
US Mountain and Western States

Tel +1-323-720-1336 1-800-826-1778  
Fax 1-800-726-1314

[support@teamboard.com](mailto:support@teamboard.com)

