

**Hardware**

1/4-20 x 1 1/2 Allen bolt x(2) 

1/2" Wood screw x(4) 

**Tools Required**

Phillips Screwdriver 

Allen key (provided) 

**Components**

①

Please make sure you have the following components prior to assembly.

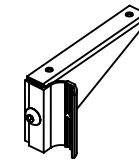
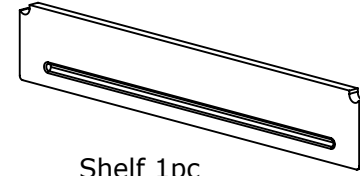

**Assembly**

②

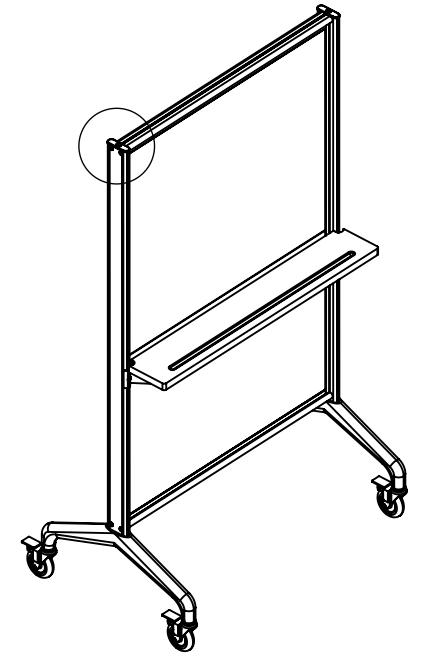
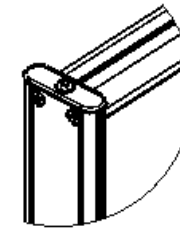

Remove the top screws as shown in **A**.

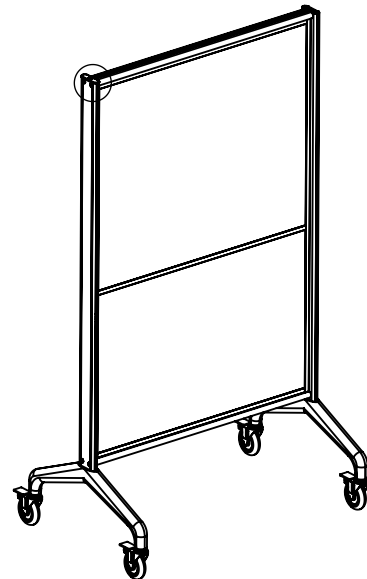
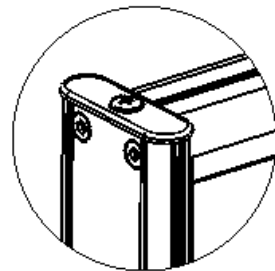
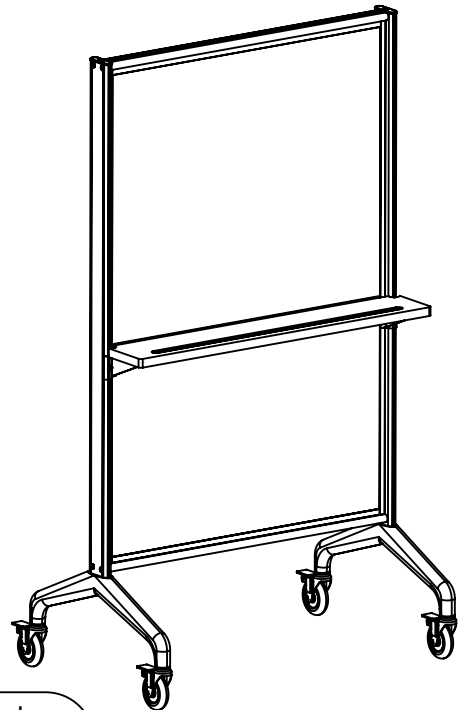

③

Place the sliding connector into the two uprights as shown in **B**. Make sure that the spring is to the back.

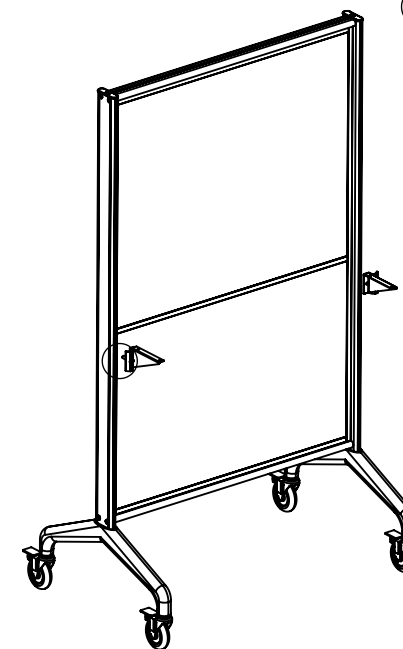
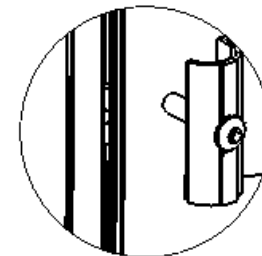

④

Position sliding connector to the desired height. Connect the shelf bracket with bolt provided.

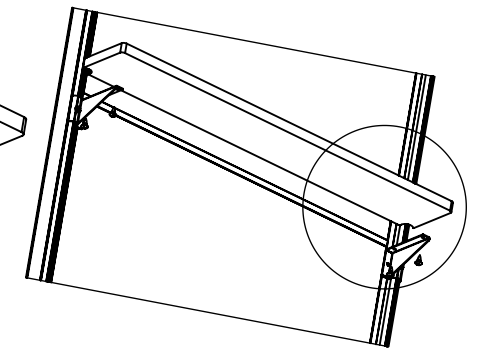
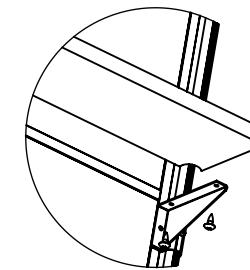

⑤

Position shelf center to center onto brackets. Attach shelf with wood screws provided.

Comments  
or  
Questions?

CALL US!

USA  
&  
CANADA : 1-800-263-2387